



ITTEST

QUESTION & ANSWER

Guías de estudio precisos, Alta tasa de paso!



Ittest ofrece información actualizada de forma gratuita en un año!

<http://www.ittest.es/>

Exam : **640-802**

Title : Cisco Certified Network
Associate(CCNA)

Version : DEMO

1.Refer to the exhibit.

What could be possible causes for the "Serial0/0 is down" interface status? (Choose two.)

```
Router# show interfaces serial 0/0
Serial0/0 is down, line protocol is down
Hardware is MK5025
Serial Internet address is 10.1.1.2/24
MTU 1500 bytes, BW 1544 Kbits, DLY 20000 usec, rely 255/255 load 9/255
Encapsulation PPP, loopback not set, keepalive set (10 sec)
```

- A. A Layer 1 problem exists.
- B. The bandwidth is set too low.
- C. A protocol mismatch exists
- D. An incorrect cable is being used.
- E. There is an incorrect IP address on the Serial 0/0 interface.

Answer: AD

2.Before installing a new, upgraded version of the IOS, what should be checked on the router, and which command should be used to gather this information? (Choose two.)

- A. the amount of available ROM
- B. the amount of available flash and RAM memory
- C. the version of the bootstrap software present on the router
- D. show version
- E. show processes
- F. show running-config

Answer: BD

3.Refer to the exhibit.

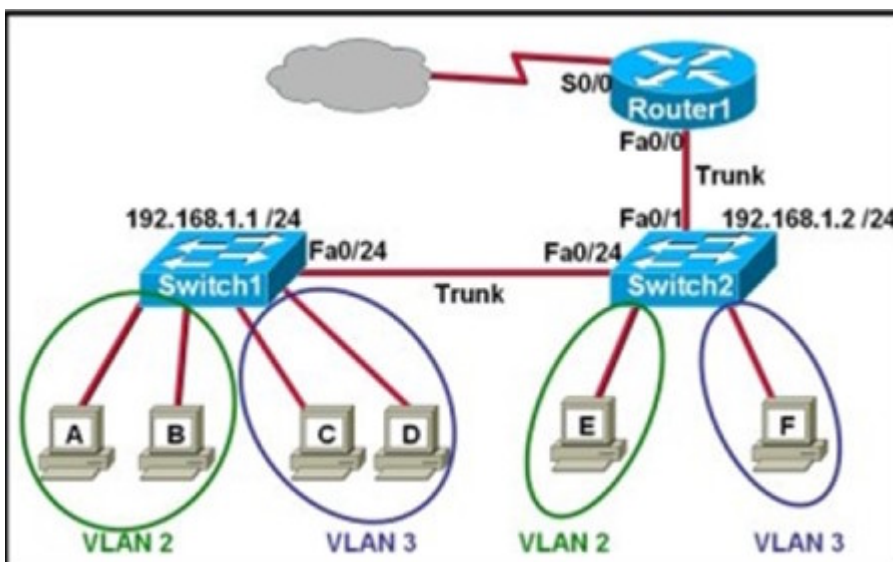

Which two statements are true about interVLAN routing in the topology that is shown in the exhibit? (Choose two.)

- A. Host E and host F use the same IP gateway address.
- B. Router1 and Switch2 should be connected via a crossover cable.

- C. Router1 will not play a role in communications between host A and host D.
- D. The FastEthernet 0/0 interface on Router1 must be configured with subinterfaces.
- E. Router1 needs more LAN interfaces to accommodate the VLANs that are shown in the exhibit.
- F. The FastEthernet 0/0 interface on Router1 and Switch2 trunk ports must be configured using the same encapsulation type.

Answer: DF

4.Refer to the exhibit.

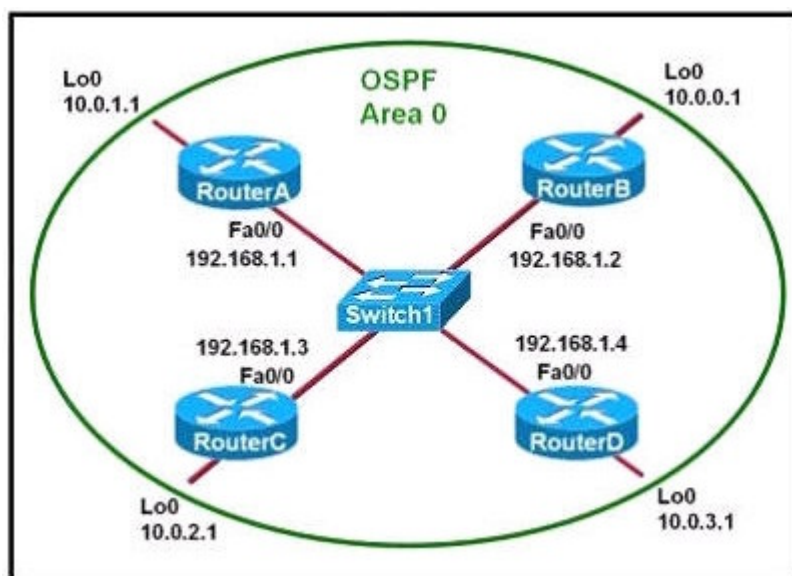

Which two statements are true about the loopback address that is configured on RouterB? (Choose two.)

- A. It ensures that data will be forwarded by RouterB.
- B. It provides stability for the OSPF process on RouterB.
- C. It specifies that the router ID for RouterB should be 10.0.0.1.
- D. It decreases the metric for routes that are advertised from RouterB.
- E. It indicates that RouterB should be elected the DR for the LAN.

Answer: BC

5.If you are a network administrator, how will you explain VTP configuration to a new technician? (Choose three.)

- A. In the VTP client mode, a switch is unable to update its local VLAN database.
- B. Configure a trunk link between the switches to forward VTP updates.
- C. In the VTP server mode, a switch is able to update a switch in the VTP transparent mode.
- D. In the VTP transparent mode, a switch will forward the received updates to other switches.
- E. A switch in the VTP server mode only updates switches in the VTP client mode that have a higher VTP revision number.
- F. A switch in the VTP server mode will update switches in the VTP client mode regardless of the configured VTP domain membership.

Answer: ABD

6.Cisco IOS (originally Internetwork Operating System) is the software used on the vast majority of Cisco

Systems routers and all current Cisco network switches.

Which two of the following devices could you configure as a source for the IOS image in the boot system command? (Choose two.)

- A. RAM
- B. NVRAM
- C. flash memory
- D. HTTP server
- E. TFTP server
- F. Telnet server

Answer: CE

7. What are two reasons a network administrator would use CDP? (Choose two.)

- A. to obtain VLAN information from directly connected switches
- B. to determine the status of network services on a remote device
- C. to determine the status of the routing protocols between directly connected routers
- D. to verify the type of cable interconnecting two devices
- E. to verify Layer 2 connectivity between two devices when Layer 3 fails
- F. to obtain the IP address of a connected device in order to telnet to the device

Answer: EF

8. Refer to the exhibit.

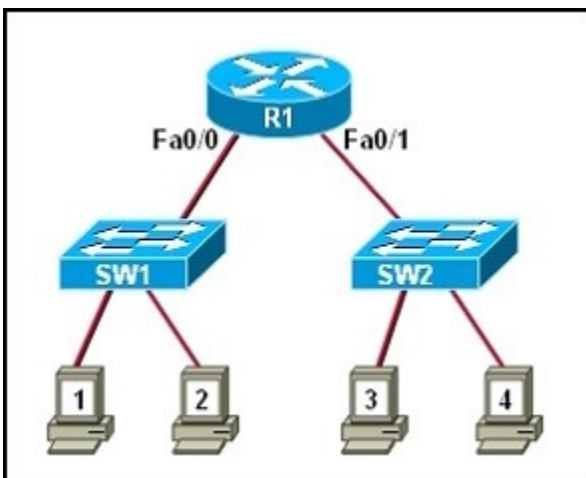

Both switches are using a default configuration.

Which two destination addresses will host 4 use to send data to host 1? (Choose two.)

- A. the IP address of host 1
- B. the IP address of host 4
- C. the MAC address of host 1
- D. the MAC address of host 4
- E. the MAC address of the Fa0/0 interface of the R1 router
- F. the MAC address of the Fa0/1 interface of the R1 router

Answer: AF

9. Refer to the exhibit.

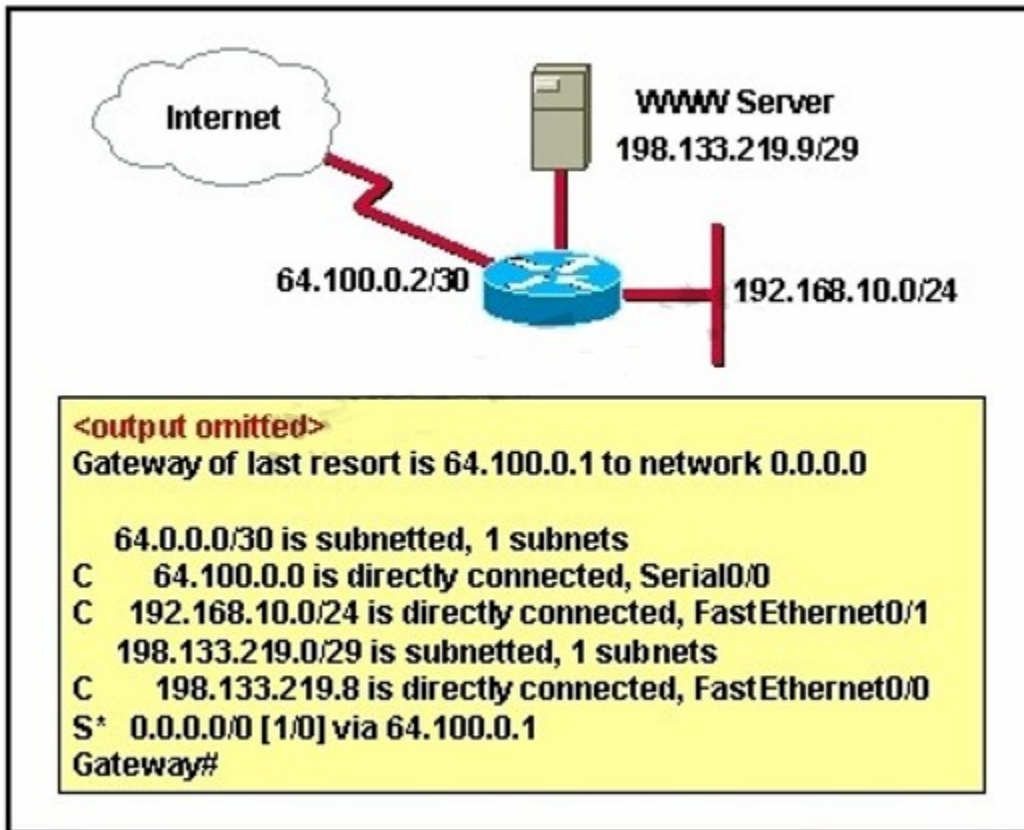

The router has been configured with these commands:

```

hostname Gateway
interface FastEthernet 0/0
ip address 198.133.219.14 255.255.255.248
no shutdown
interface FastEthernet 0/1
ip address 192.168.10.254 255.255.255.0
no shutdown
interface Serial 0/0
ip address 64.100.0.2 255.255.255.252
no shutdown
ip route 0.0.0.0 0.0.0.0 64.100.0.1
    
```

What are the two results of this configuration? (Choose two.)

- A. The default route should have a next hop address of 64.100.0.3.
- B. Hosts on the LAN that is connected to FastEthernet 0/1 are using public IP addressing.
- C. The address of the subnet segment with the WWW server will support seven more servers.
- D. The addressing scheme allows users on the Internet to access the WWW server.
- E. Hosts on the LAN that is connected to FastEthernet 0/1 will not be able to access the Internet without address translation.

Answer: DE

10. Your Company has installed IP phones. Both the phones and the office computers connect to the same device.

The phone traffic and the office computer data traffic must be on different networks to ensure maximum

throughput for the phone data.

Which network device can be best connected to the phones and computers, and which technology will be performed on this device? (Choose two.)

- A. hub
- B. router
- C. switch
- D. stp
- E. subinterfaces
- F. VLAN

Answer: CF

11.Which two benefits can be obtained by using VTP in a switching environment? (Choose two.)

- A. Allowing frames from multiple VLANs to use a single interface.
- B. Allowing switches to read frame tags.
- C. Maintaining VLAN consistency across a switched network.
- D. Allowing VLAN information to be automatically propagated throughout the switching environment.
- E. It allows ports to be assigned to VLANs automatically.

Answer: CD

12.Which two statements are true about the command ip route 172.16.3.0 255.255.255.0 192.168.2.4? (Choose two.)

- A. It establishes a static route to the 172.16.3.0 network.
- B. It configures the router to send any traffic for an unknown destination to the 172.16.3.0 network.
- C. It creates a static route to the 192.168.2.0 network.
- D. It uses the default administrative distance.
- E. It configures the router to send any traffic for an unknown destination out the interface with the address 192.168.2.4.
- F. It is a route that would be used last if other routes to the same destination exist.

Answer: AD

13.Which two of the following are advantages of Layer 2 Ethernet switches over hubs? (Choose two.)

- A. To increase the size of broadcast domains
- B. To filter frames according to MAC addresses
- C. To allow simultaneous frame transmissions
- D. To increase the maximum length of UTP cabling between devices
- E. decreasing the number of collision domains
- F. increasing the size of broadcast domains

Answer: BC

14.Refer to the exhibit.

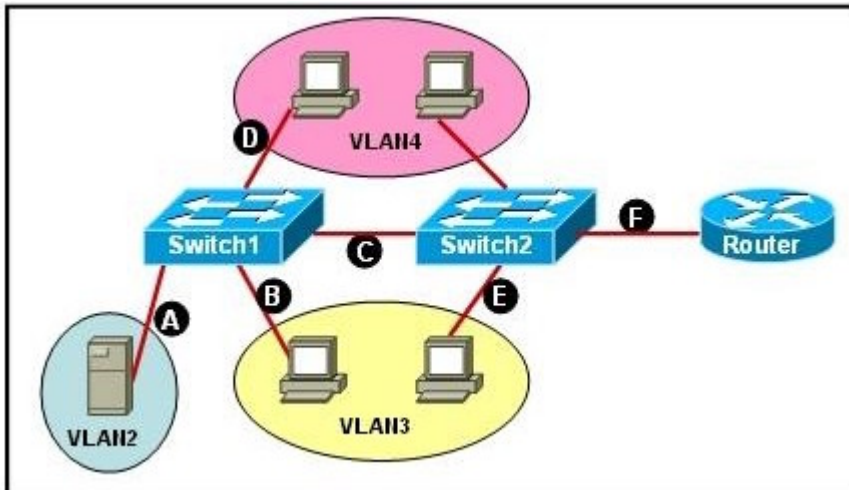

A network associate needs to configure the switches and router in the graphic so that the hosts in VLAN3 and VLAN4 can communicate with the enterprise server in VLAN2.

Which two Ethernet segments would need to be configured as trunk links? (Choose two.)

- A. A
- B. B
- C. C
- D. D
- E. E
- F. F

Answer: CF

15. Which two values are used by Spanning Tree Protocol to elect a root bridge? (Choose two.)

- A. bridge priority
- B. IP address
- C. MAC address
- D. IOS version
- E. amount of RAM
- F. speed of the links

Answer: AC

16. Refer to the exhibit.

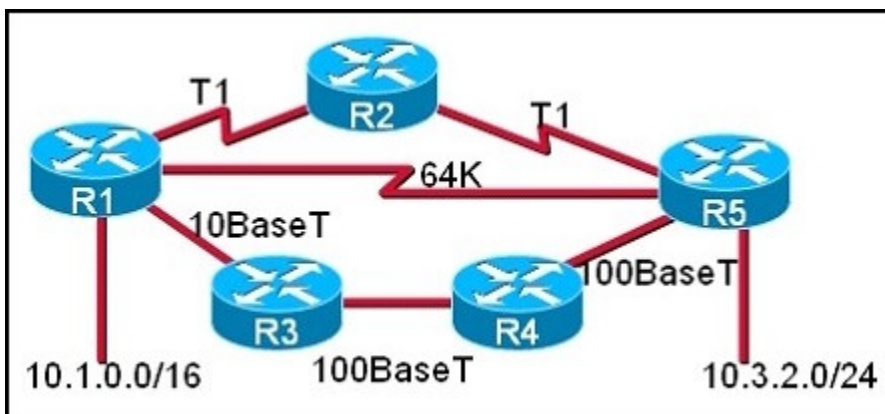

Assume that the routing protocol referenced in each choice below is configured with its default settings and the given routing protocol is running on all the routers.

Which two conditional statements accurately state the path that will be chosen between networks 10.1.0.0 and 10.3.2.0 for the routing protocol mentioned? (Choose two.)

- A. If OSPF is the routing protocol, the path will be from R1 to R3 to R4 to R5.
- B. If OSPF is the routing protocol, the path will be from R1 to R2 to R5.
- C. If OSPF is the routing protocol, the path will be from R1 to R5.
- D. If RIPv2 is the routing protocol, the path will be from R1 to R3 to R4 to R5.
- E. If RIPv2 is the routing protocol, the path will be from R1 to R5.

Answer: AE

17.Refer to the exhibit.

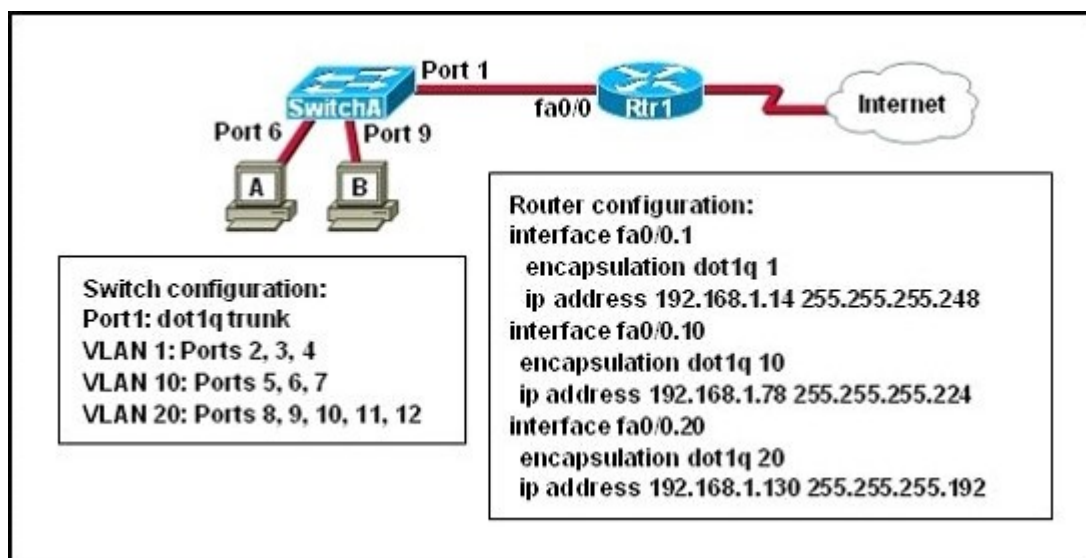

A network administrator is adding two new hosts to SwitchA.

Which three values could be used for the configuration of these hosts? (Choose three.)

- A. host A IP address: 192.168.1.79
- B. host A IP address: 192.168.1.64
- C. host A default gateway: 192.168.1.78
- D. host B IP address: 192.168.1.128
- E. host B default gateway: 192.168.1.129
- F. host B IP address: 192.168.1.190

Answer: ACF

18.What will happen after changing the configuration register to 0x2142 and rebooting the router? (Choose two.)

- A. The IOS image will be ignored.
- B. The router will prompt to enter initial configuration mode.
- C. The router will boot to ROM.
- D. Any configuration entries in NVRAM will be ignored.
- E. The configuration in flash memory will be booted.

Answer: BD

19.Refer to the exhibit.

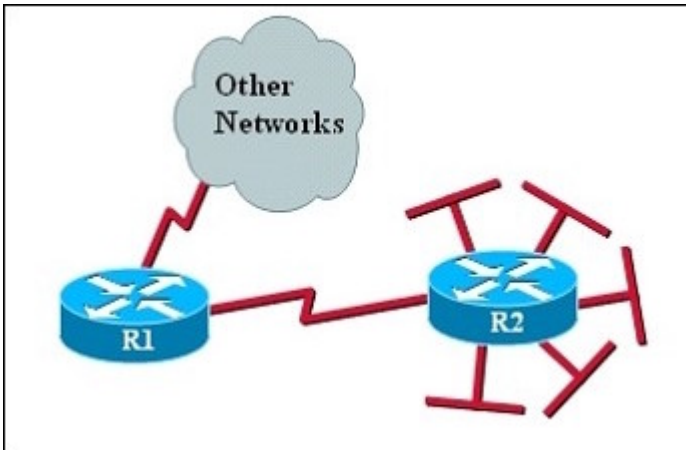

The networks connected to router R2 have been summarized as a 192.168.176.0/21 route and sent to R1.

Which two packet destination addresses will R1 forward to R2? (Choose two.)

- A. 192.168.194.160
- B. 192.168.183.41
- C. 192.168.159.2
- D. 192.168.183.255
- E. 192.168.179.4
- F. 192.168.184.45

Answer: BE

20.Which three statements are typical characteristics of VLAN arrangements? (Choose three.)

- A. A new switch has no VLANs configured.
- B. Connectivity between VLANs requires a Layer 3 device.
- C. VLANs typically decrease the number of collision domains.
- D. Each VLAN uses a separate address space.
- E. A switch maintains a separate bridging table for each VLAN.
- F. VLANs cannot span multiple switches.

Answer: BDE

21.Refer to the exhibit.

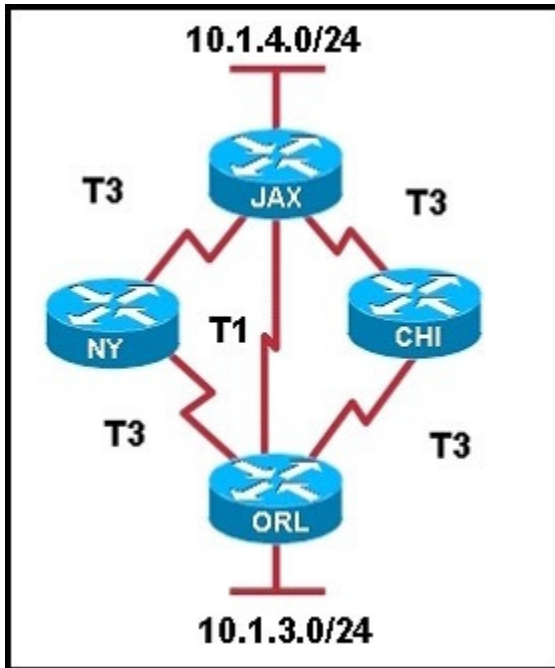

Which three statements are true about how router JAX will choose a path to the 10.1.3.0/24 network when different routing protocols are configured? (Choose three.)

- A. By default, if RIPv2 is the routing protocol, only the path JAX-ORL will be installed into the routing table.
- B. The equal cost paths JAX-CHI-ORL and JAX- NY-ORL will be installed in the routing table if RIPv2 is the routing protocol.
- C. When EIGRP is the routing protocol, only the path JAX-ORL will be installed in the routing table by default.
- D. When EIGRP is the routing protocol, the equal cost paths JAX-CHI-ORL, and JAX-NY-ORL will be installed in the routing table by default.
- E. With EIGRP and OSPF both running on the network with their default configurations, the EIGRP paths will be installed in the routing table.
- F. The OSPF paths will be installed in the routing table, if EIGRP and OSPF are both running on the network with their default configurations.

Answer: ADE

22.Refer to the exhibit.

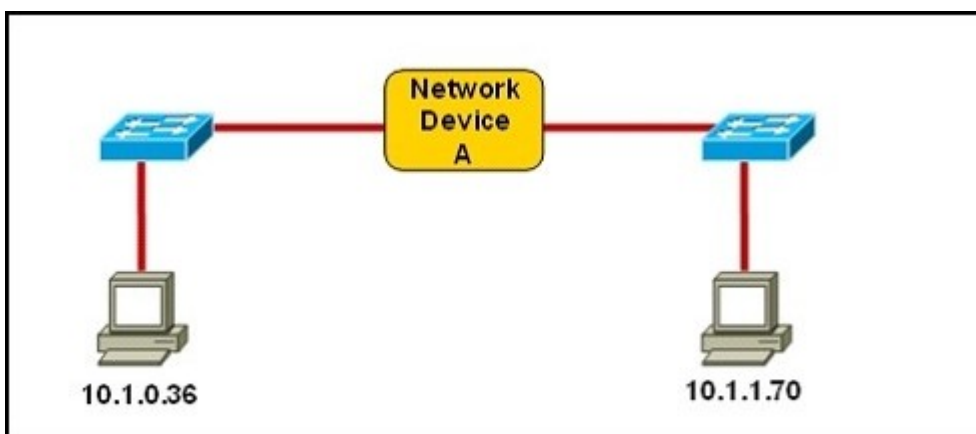

Which three statements correctly describe Network Device A? (Choose three.)

- A. With a network wide mask of 255.255.255.128, each interface does not require an IP address.
- B. With a network wide mask of 255.255.255.128, each interface does require an IP address on a unique IP subnet.
- C. With a network wide mask of 255.255.255.0, must be a Layer 2 device for the PCs to communicate with each other.
- D. With a network wide mask of 255.255.255.0, must be a Layer 3 device for the PCs to communicate with each other.
- E. With a network wide mask of 255.255.254.0, each interface does not require an IP address.

Answer: BDE

23. On the basis of the IEEE 802.1w standard, which two switch ports can forward traffic?

- A. alternate
- B. backup
- C. designated
- D. disabled
- E. root

Answer: CE

24. Refer to the exhibit.

```
Switch# show spanning-tree interface fastethernet0/10
Vlan          Role Sts Cost          Prio.Nbr Type
-----
VLAN0001      Root FWD 19            128.1    P2p
VLAN0002      Altn BLK 19            128.2    P2p
VLAN0003      Root FWD 19            128.2    P2p
```

Given the output shown from this Cisco Catalyst 2950, what is the most likely reason that interface FastEthernet 0/10 is not the root port for VLAN 2?

- A. This switch has more than one interface connected to the root network segment in VLAN 2.
- B. This switch is running RSTP while the elected designated switch is running 802.1d Spanning Tree.
- C. This switch interface has a higher path cost to the root bridge than another in the topology.
- D. This switch has a lower bridge ID for VLAN 2 than the elected designated switch.

Answer: C

25. Refer to the exhibit.

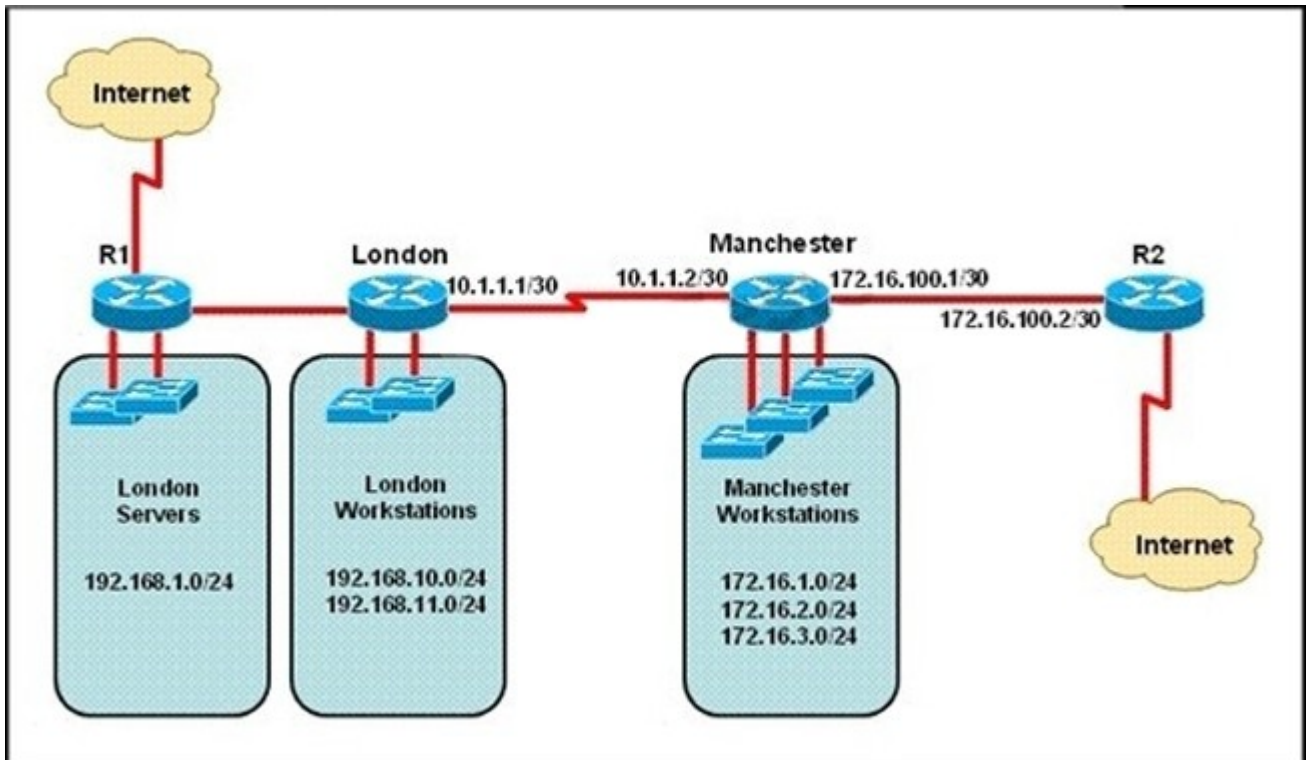

The network administrator must establish a route by which London workstations can forward traffic to the Manchester workstations.

What is the simplest way to accomplish this?

- A. Configure a dynamic routing protocol on London to advertise all routes to Manchester.
- B. Configure a dynamic routing protocol on London to advertise summarized routes to Manchester.
- C. Configure a dynamic routing protocol on Manchester to advertise a default route to the London router.
- D. Configure a static default route on London with a next hop of 10.1.1.1.
- E. Configure a static route on London to direct all traffic destined for 172.16.0.0/22 to 10.1.1.2.
- F. Configure Manchester to advertise a static default route to London.

Answer: E

26.Refer to the exhibit.

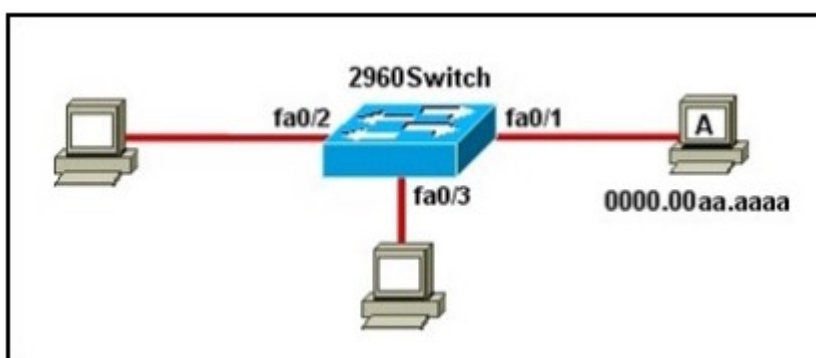

This command is executed on 2960Switch:

```
2960Switch (config)# mac-address-table static 0000.00aa.aaaa vlan 10 interface fa0/1
```

Which two of these statements correctly identify results of executing the command? (Choose two.)

- A. Port security is implemented on the fa0/1 interface.

- B. MAC address 0000.00aa.aaaa does not need to be learned by this switch.
- C. Only MAC address 0000.00aa.aaaa can source frames on the fa0/1 segment.
- D. Frames with a Layer 2 source address of 0000.00aa.aaaa will be forwarded out fa0/1.
- E. MAC address 0000.00aa.aaaa will be listed in the MAC address table for interface fa0/1 only.

Answer: BE

27. Which of the following describes the roles of devices in a WAN? (Choose three.)

- A. A CSU/DSU terminates a digital local loop.
- B. A modem terminates a digital local loop.
- C. A CSU/DSU terminates an analog local loop.
- D. A modem terminates an analog local loop.
- E. A router is commonly considered a DTE device.
- F. A router is commonly considered a DCE device.

Answer: ADE

28. What are two characteristics of Telnet? (Choose two.)

- A. It sends data in clear text format.
- B. It is no longer supported on Cisco network devices.
- C. It is more secure than SSH.
- D. It requires an enterprise license in order to be implemented.
- E. It requires that the destination device be configured to support Telnet connections.

Answer: AE

29. Which two security appliances will you use in a network? (Choose two.)

- A. ATM
- B. ids
- C. ios
- D. iox
- E. ips
- F. SDM

Answer: BE

30. A single 802.11g access point has been configured and installed in the center of a square office. A few wireless users are experiencing slow performance and drops while most users are operating at peak efficiency.

What are three likely causes of this problem? (Choose three.)

- A. mismatched TKIP encryption
- B. null SSID
- C. cordless phones
- D. mismatched SSID
- E. metal file cabinets
- F. antenna type or direction

Answer: CEF